

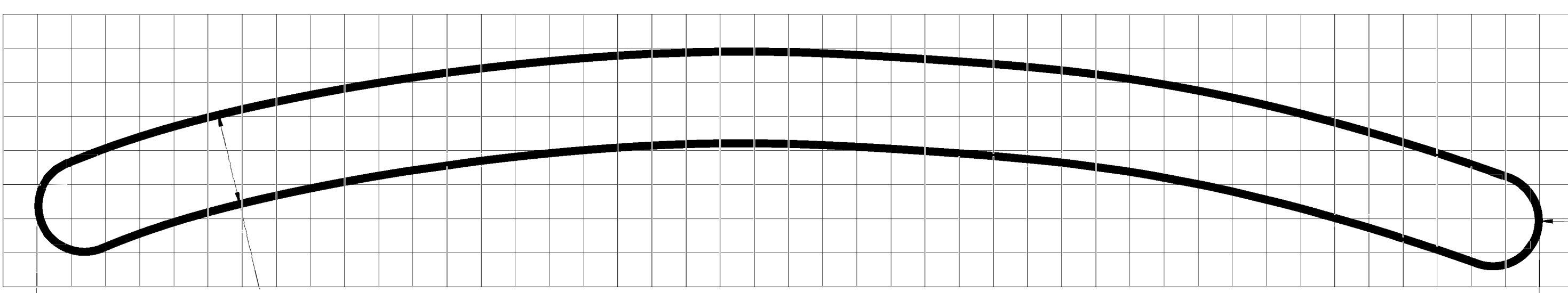

Berg's Nesting / Fire Pit Camp Chair

Table of Contents

<u>Content</u>	<u>Pg.</u>
1. Detailed Drawing	2
2. Instructions for making full sized stiles from pdf	3
3. Back Stile pdf	4-8
4. Seat Stile pdf	9-13



Back Rest Stile Front view
Scale: 1:3
Grid: 1" spacing

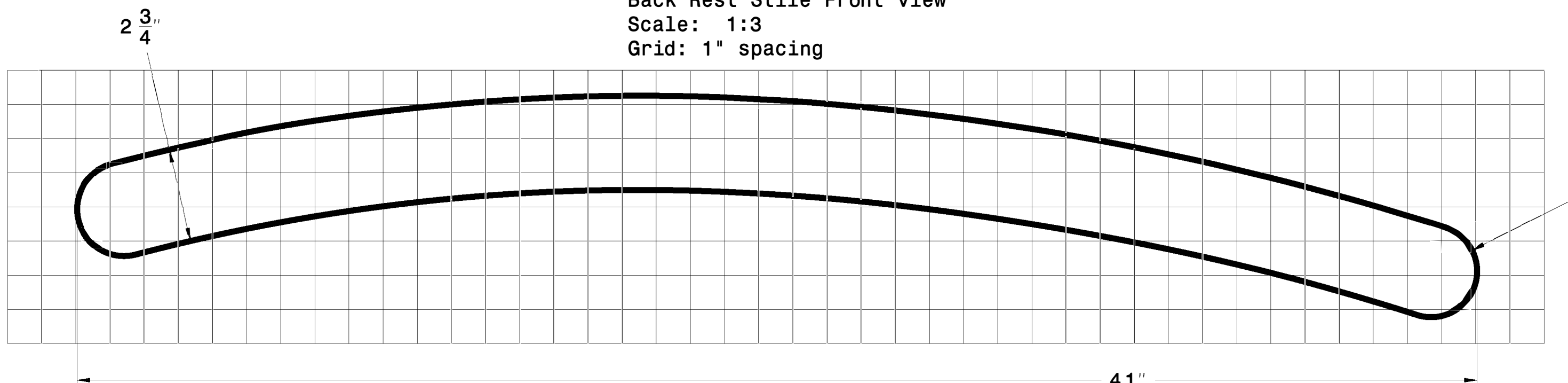

Seat Stile Front View
Scale: 1:3
Grid: 1" Spacing

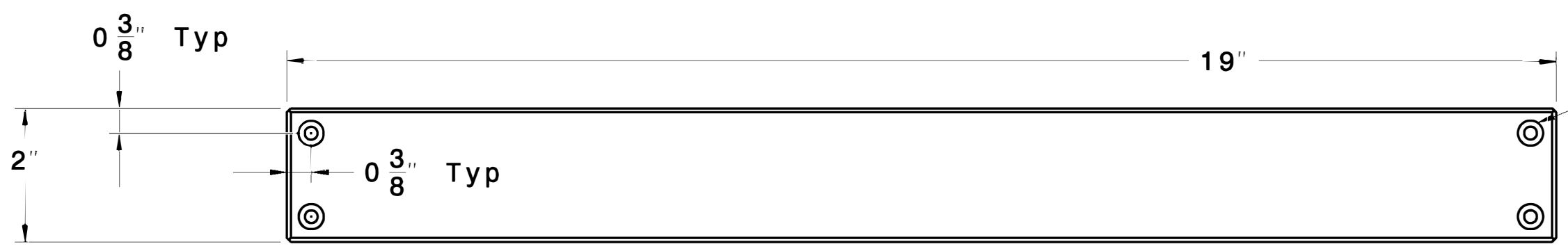

Back Cleat view
Scale: 1:2

Drill and C'Sink for #8 wood screw
Typ 4-places

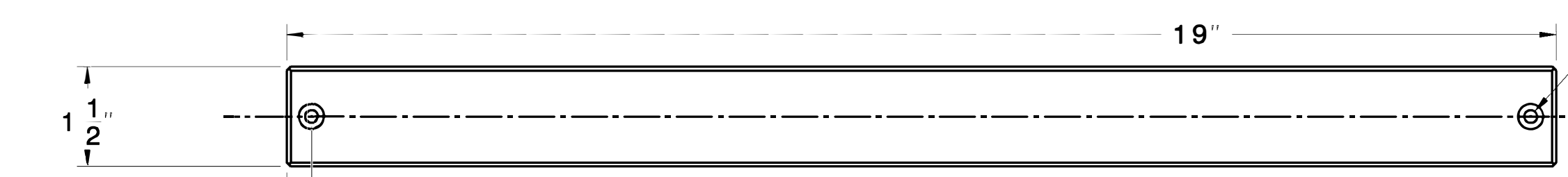

Back Slat view
Scale: 1:2

Drill and C'Sink for #8 wood screw
Typ 2-places

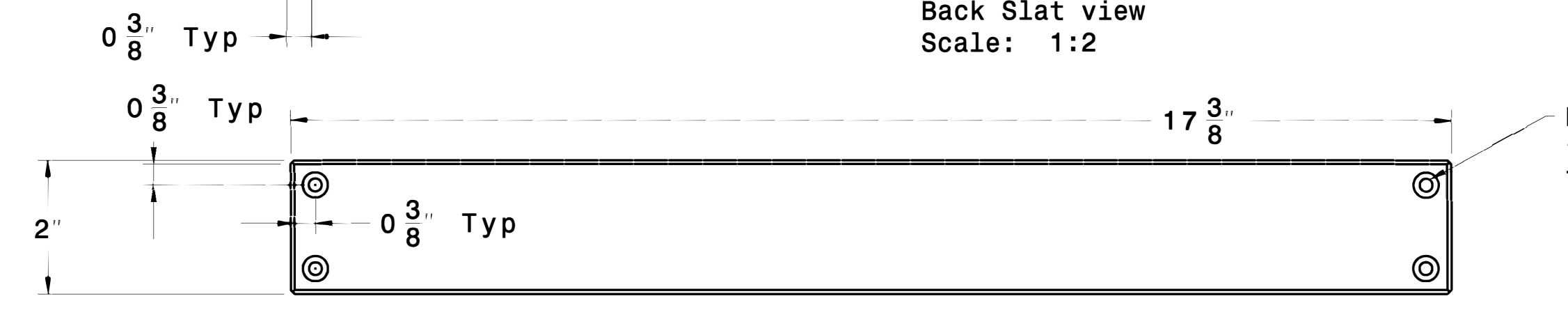

Seat Cleat view
Scale: 1:2

Drill and C'Sink for #8 wood screw
Typ 4-places

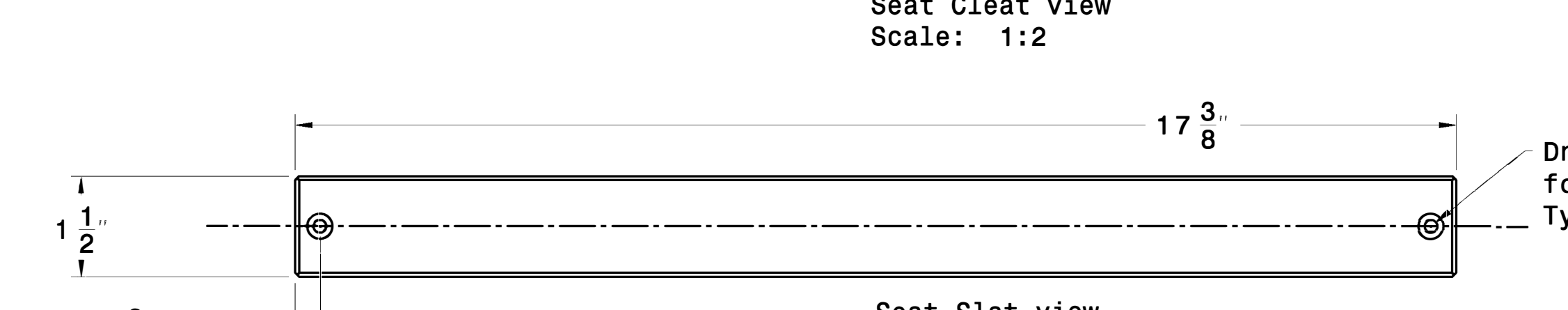

Seat Slat view
Scale: 1:2

Drill and C'Sink for #8 wood screw
Typ 2-places

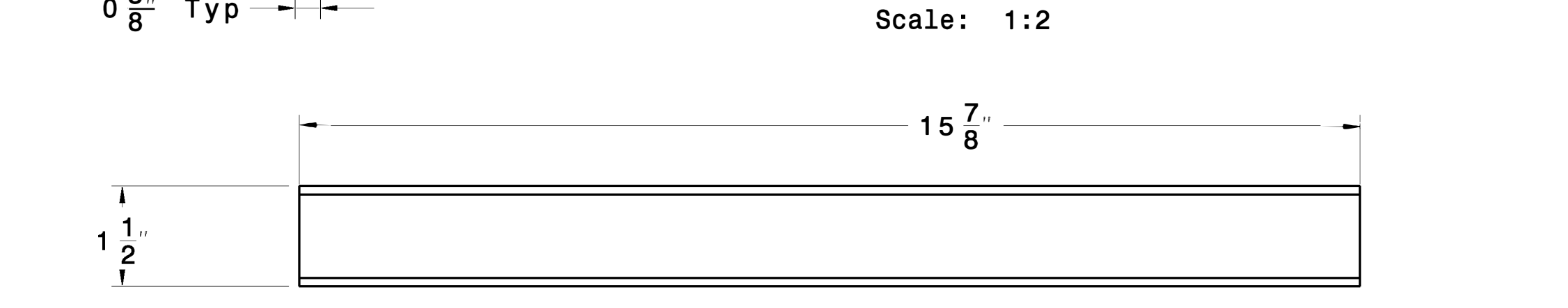

Seat Stretcher view
Scale: 1:2

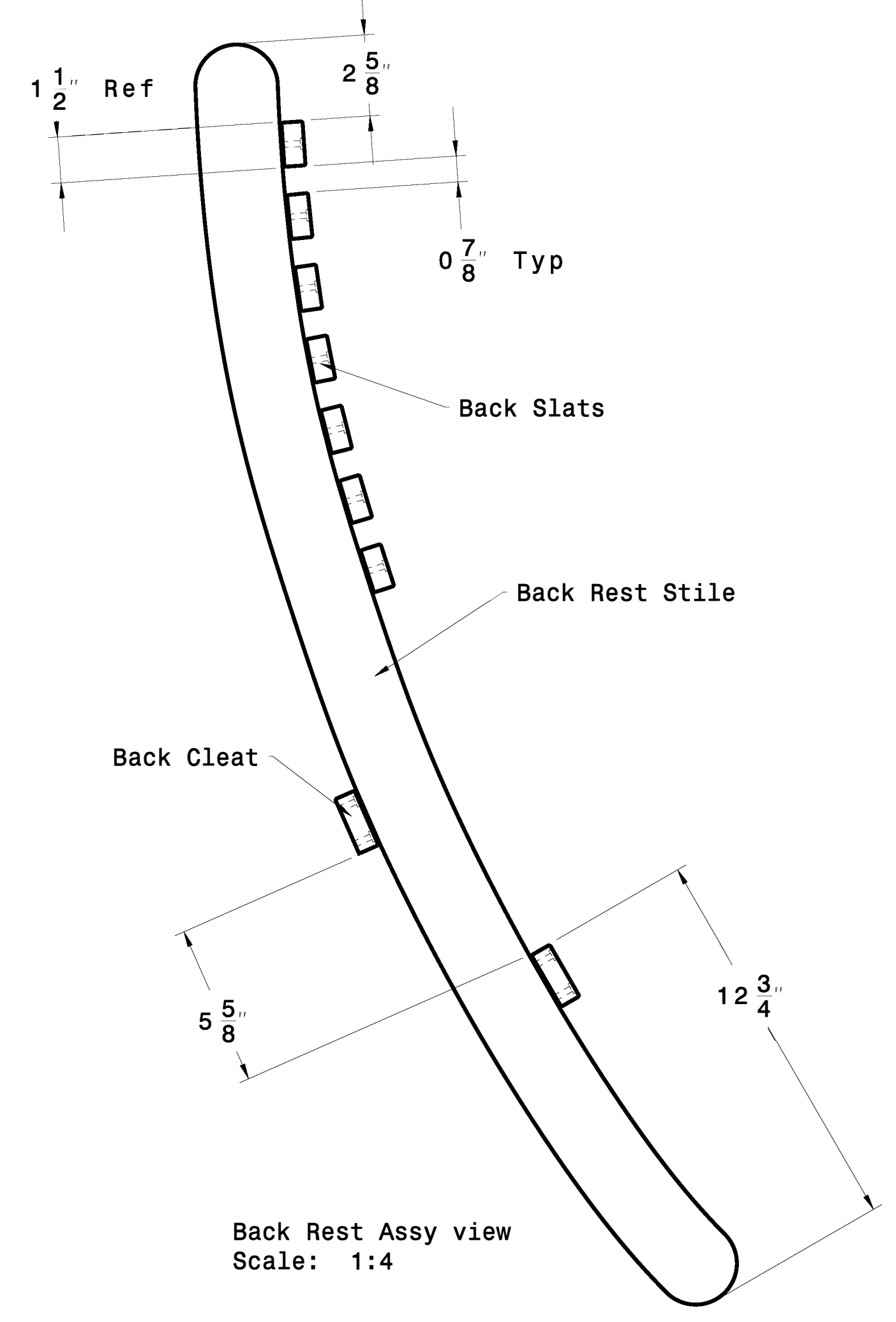

Back Rest Assy view
Scale: 1:4

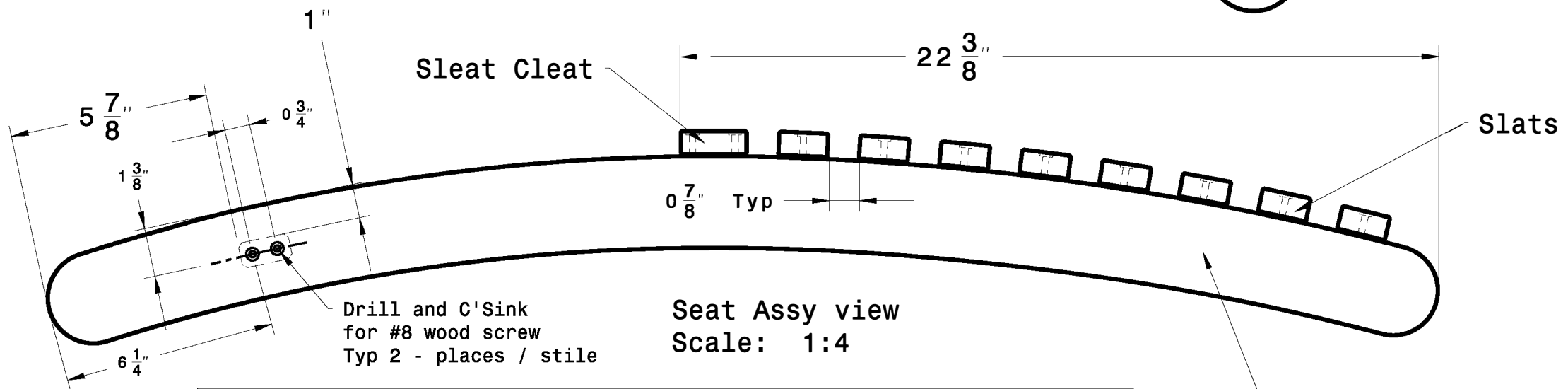

Seat Assy view
Scale: 1:4

Drill and C'Sink for #8 wood screw
Typ 2 - places / stile

MATERIAL LIST			
Component Description	Number Req'd	Size	Material
Back Rest Stile	2	44" x 6-1/2" x 3/4"	White Oak
Seat Rest Stile	2	41" x 6-1/2" x 3/4"	White Oak
Back Cleat	2	19" x 2" x 3/4"	White Oak
Back Slats	7	19" x 1-1/2" x 3/4"	White Oak
Seat Cleat	1	17-3/8" x 2" x 3/4"	White Oak
Seat Slats	8	17-3/8" x 1-1/2" x 3/4"	White Oak
Seat Stretcher	1	15-7/8" x 1-1/2" x 3/4"	White Oak
Wood Screw	46	#8 x 1-5/8"	Stainless Steel
Wood Plugs	46	3/8" Dia.	White Oak
Epoxy - Clear	1	Small Tube	
Glue -Titebond III	1	4 oz Tube	

- Notes:
- The sturdiness of the chair is related to how closely the seat and back sections fit together. Since the stiles are curved, I flatten the areas under which each slat and cleat will rest. This provides more contact area for the slat and cleat to sit on the stiles and greater gluing area.
 - All slats, cleats and stretchers are glued and screwed to the stiles. The bottom end area of stiles are sealed with epoxy for protection from ground and moisture.
 - All slats, stretchers and stiles should have rounded over or chamfered edges. I use a 1/8" radius roundover bit.
- Screws: 2 screws per slat
4 screws per cleat
4 screws per stretcher
- Finish: Use outdoor oil-based finish, such as spar varnish, tung oil or teak oil

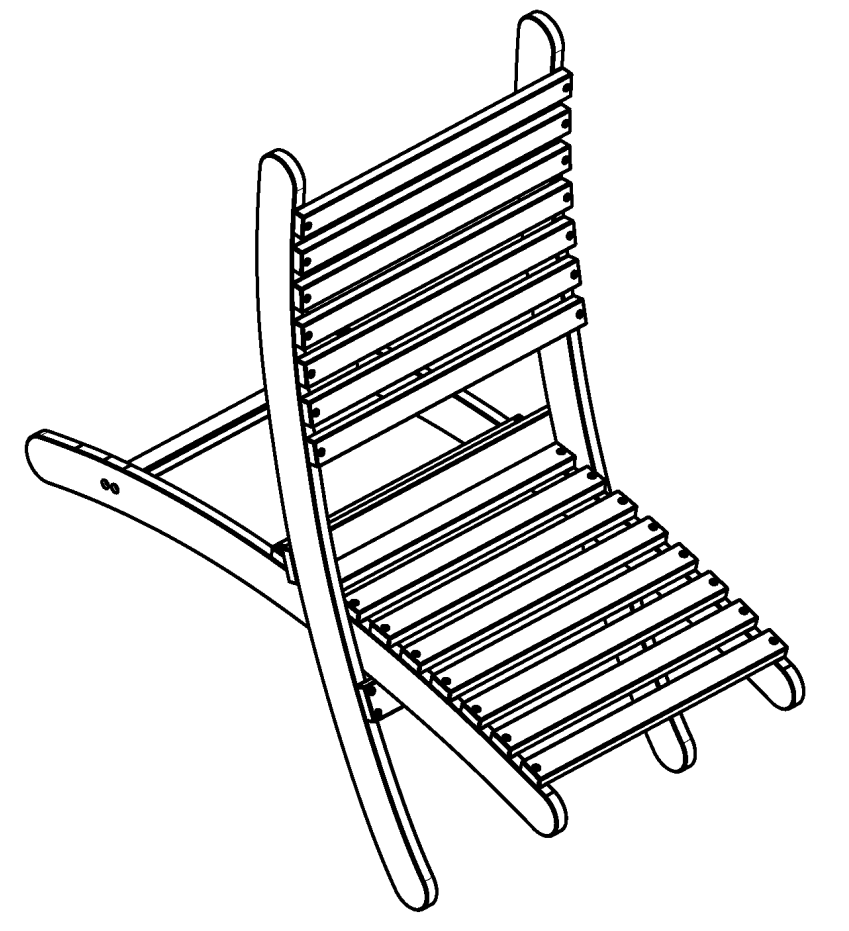

Berg's Camp Chair Isometric view
Scale: 1:10

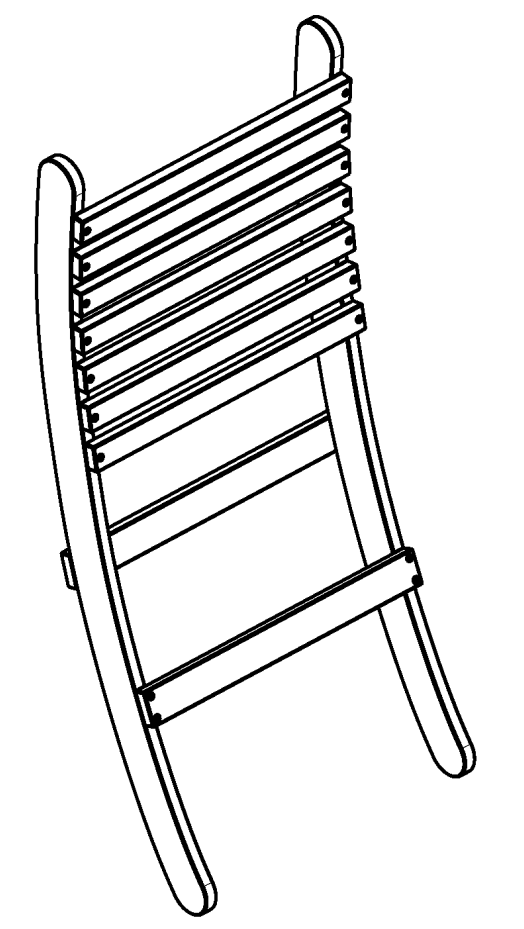

Backrest Assy Isometric view
Scale: 1:10

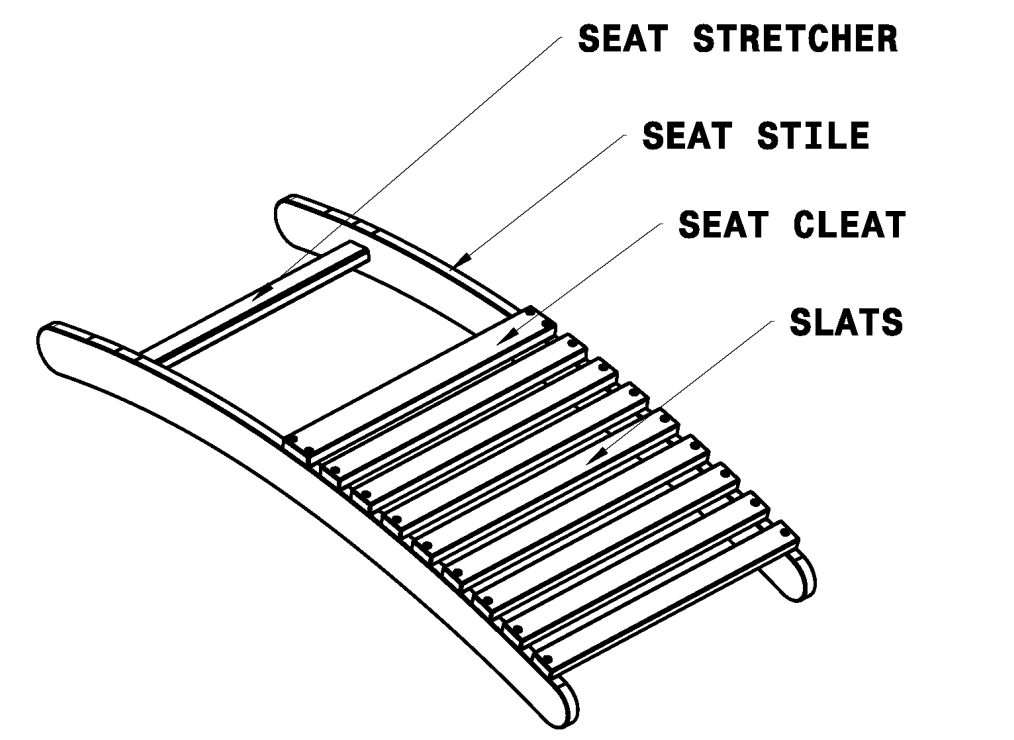

Seat Assy Isometric view
Scale: 1:10

This drawing is our property. It can't be reproduced or communicated without our written agreement.

DRAWN BY: D.R. McCAGG
DATE: 4AUG2023

CHECKED BY: XXX
DATE: XXX

DESIGNED BY: D.R. McCAGG
DATE: 4AUG2023

RAGNAR BERGETHON DESIGN			
DRAWING TITLE			
BERG'S FIRE PIT CHAIR			
DRAWN BY	DATE	SIZE	DRAWING NUMBER
D.R. McCAGG	4AUG2023	D	Bergs Chair 7-22-23
CHECKED BY	DATE	REV	
XXX	XXX	B	
DESIGNED BY	DATE	SCALE AS SHOWN	WEIGHT (kg)
D.R. McCAGG	4AUG2023		81.88
SHEET		1/1	



Duplicating Berg's Nesting / Fire Pit Camp Chair Stiles

3/10/24

- I. These files are in PDF. As such, when you print out the PDFs the picture size may need to be adjusted to match the actual stile size.
- II. Steps to adjusting the page print size:
 - a. Print out only the 1st page of each stile.
 - b. There is a 6" ruler on the right side of the page.
 - c. Compare the printer ruler size to an actual ruler size of 6".
 - d. If they are different, then adjust the printer to magnify or reduce the picture size until the ruler size on the picture measures 6".
 - e. Once the print size is adjusted, then print out all pages.
- III. Assemble the pages to make a full size stile:
 - a. Each page has alignment cross hair indexes at the upper and lower parts of each page.
 - b. Line up the cross indexes on the bottom of page 1 with the cross indexes on the top of page 2 and tape the 2 pages together.
 - c. If you place the 2 pages against a window, it will be easier to see the cross indexes.
 - d. Complete this process for attaching the remaining pages.
- IV. Glue these stiles onto your template material and trim to final shape.

FIRE PIT CHAIR

BERGETHON

BACK STILE

2/5/2024

Backrest

Stile

Pg 4/13

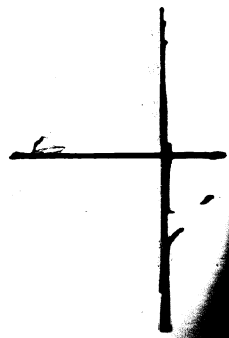
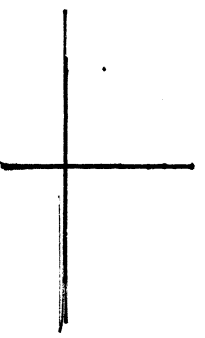
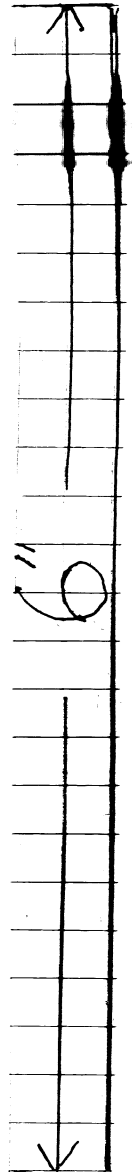
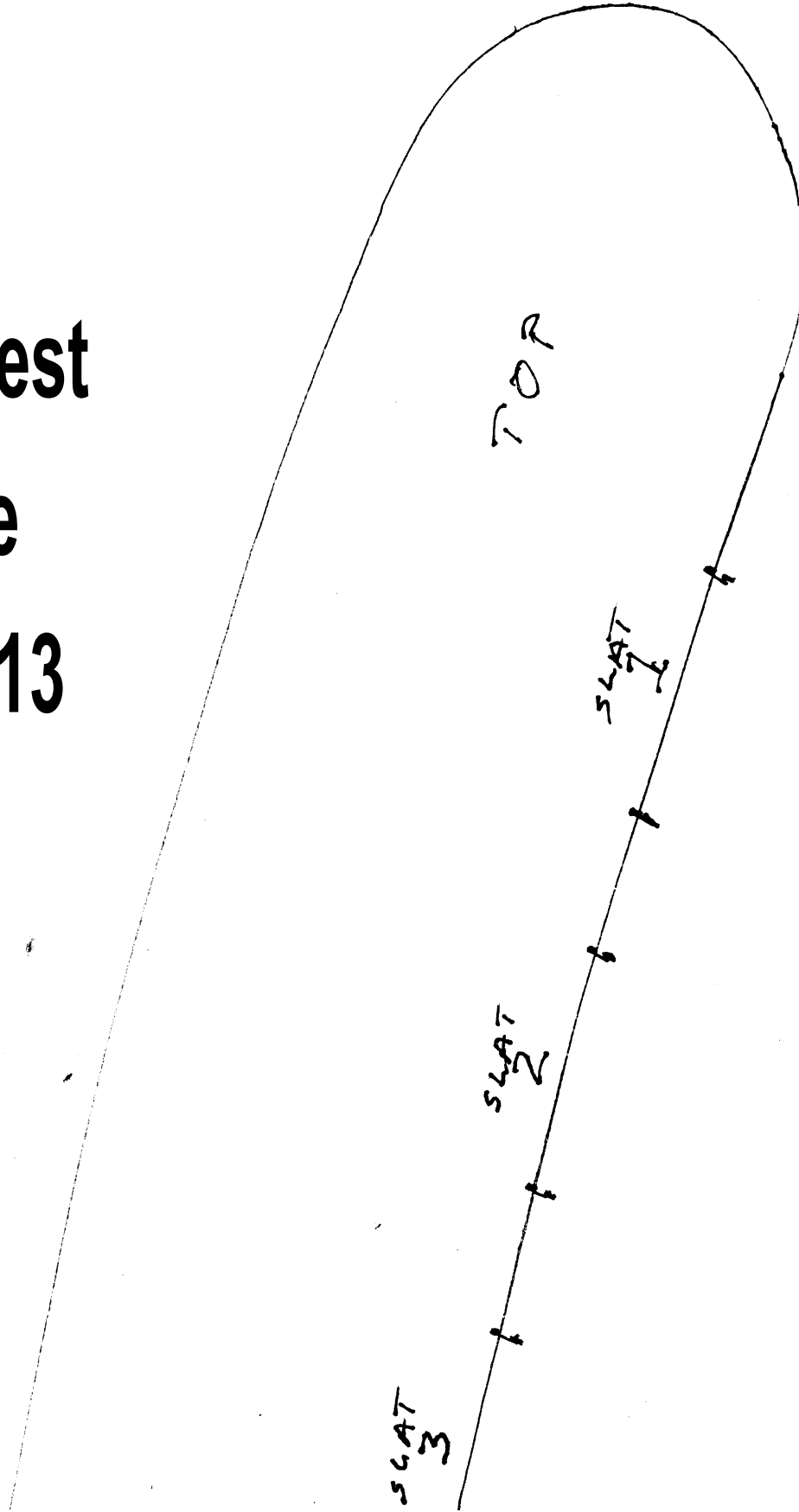

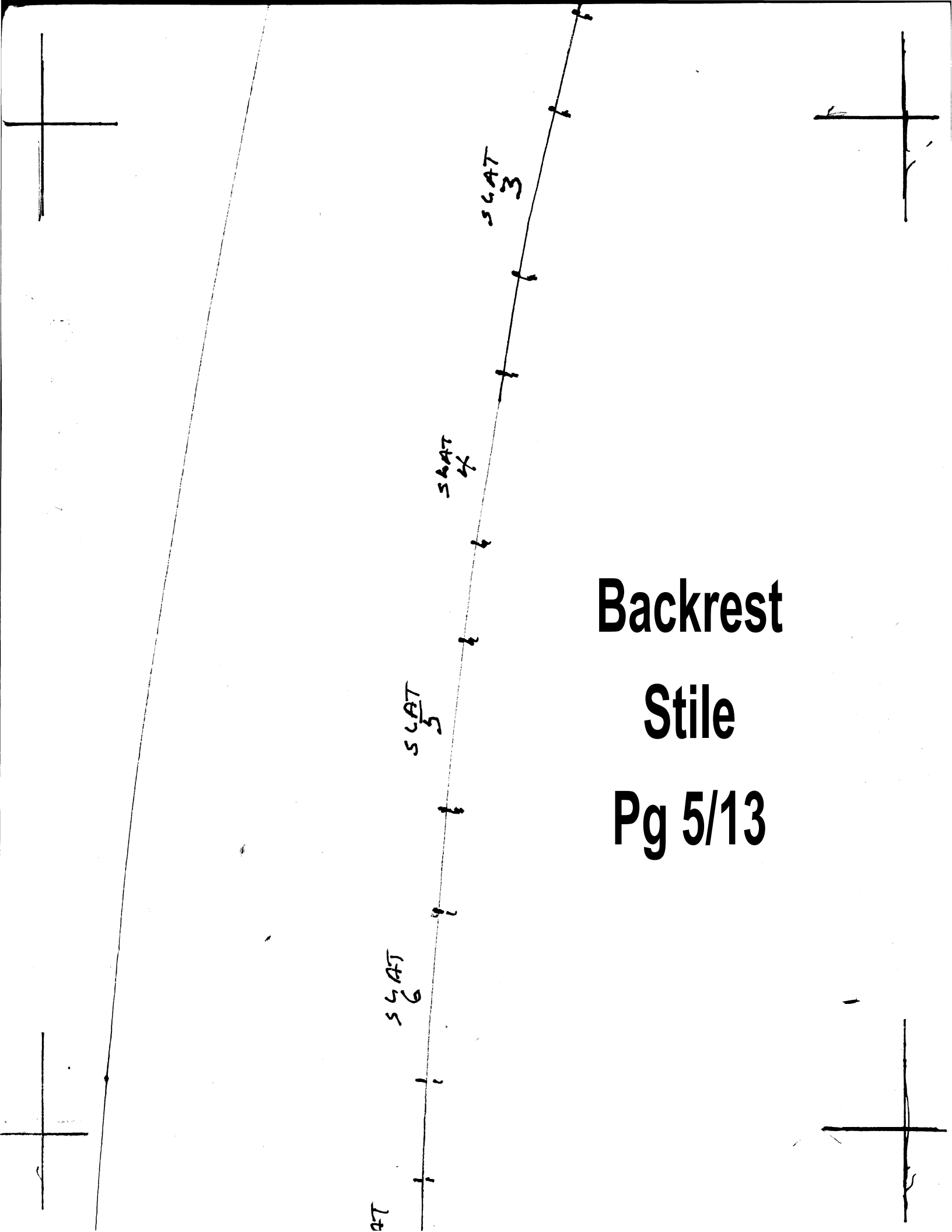

Backrest

Stile

Pg 5/13

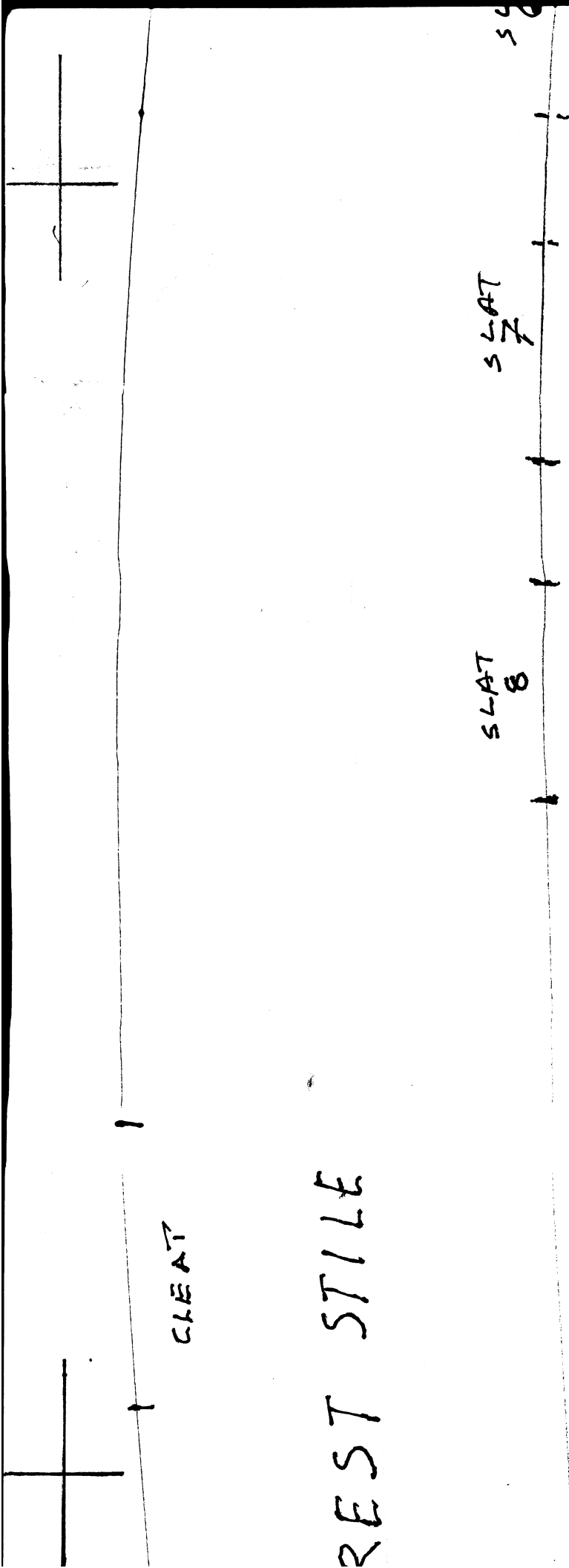

**Backrest
Stile
Pg 6/13**

BACK REST

**Backrest
Stile
Pg 7/13**

CLEAT

**Backrest
Stile
Pg 8/13**

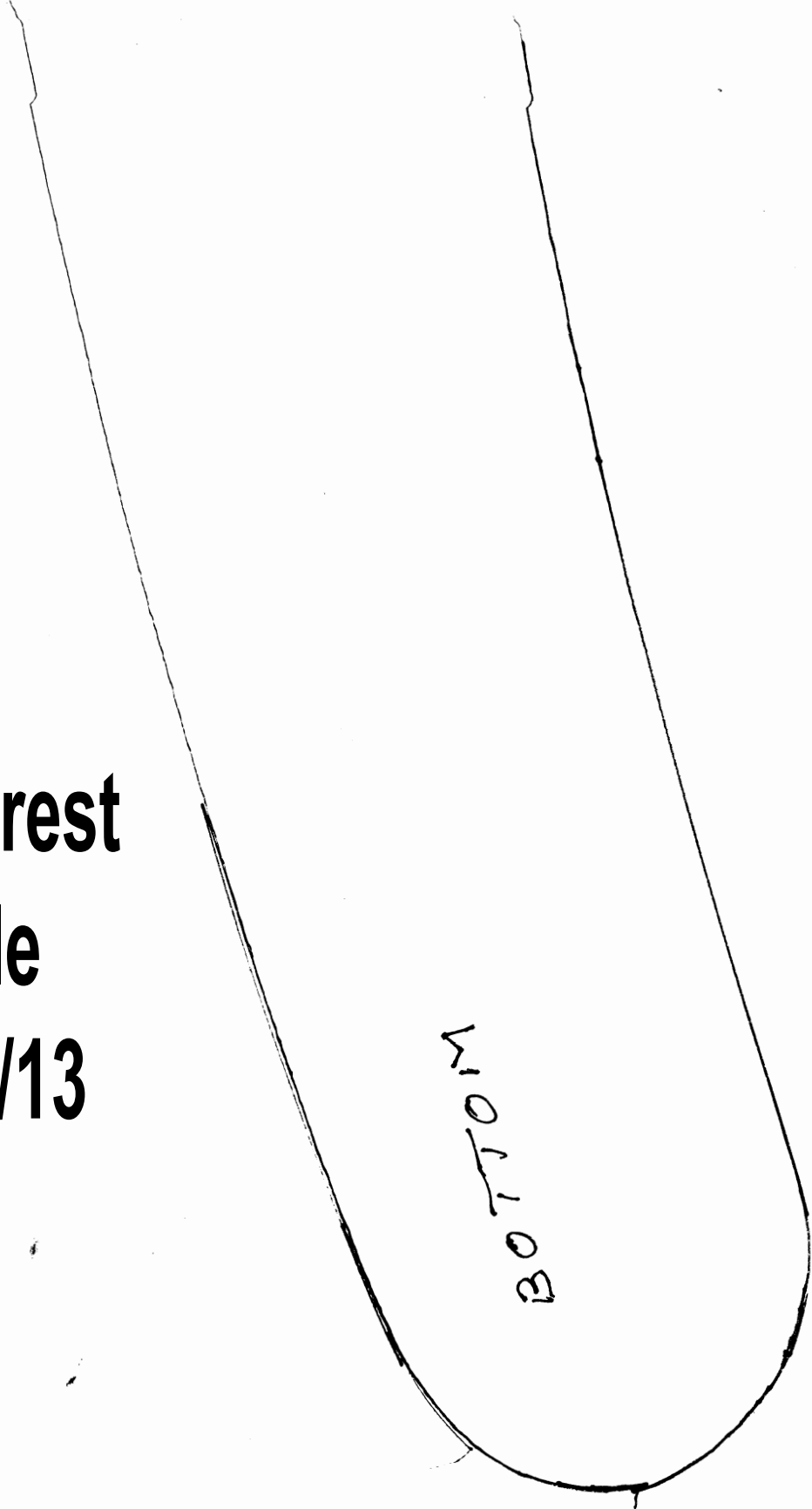

FIRE PLT CHAIR

Seat
Stile
Pg 9/13

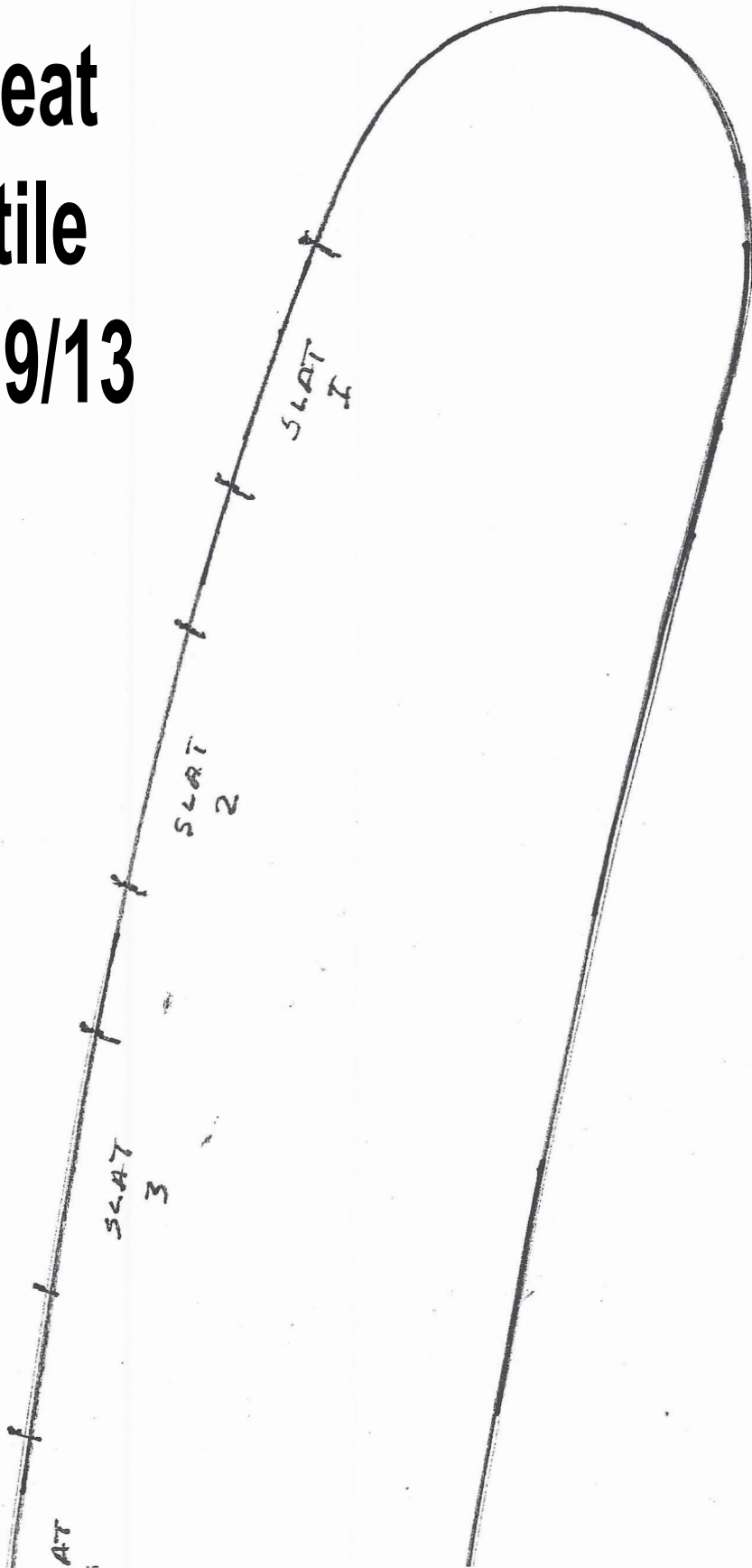

11

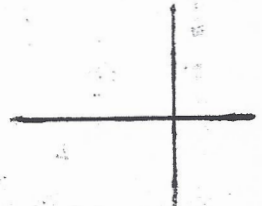
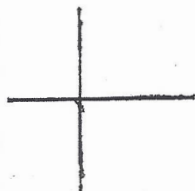

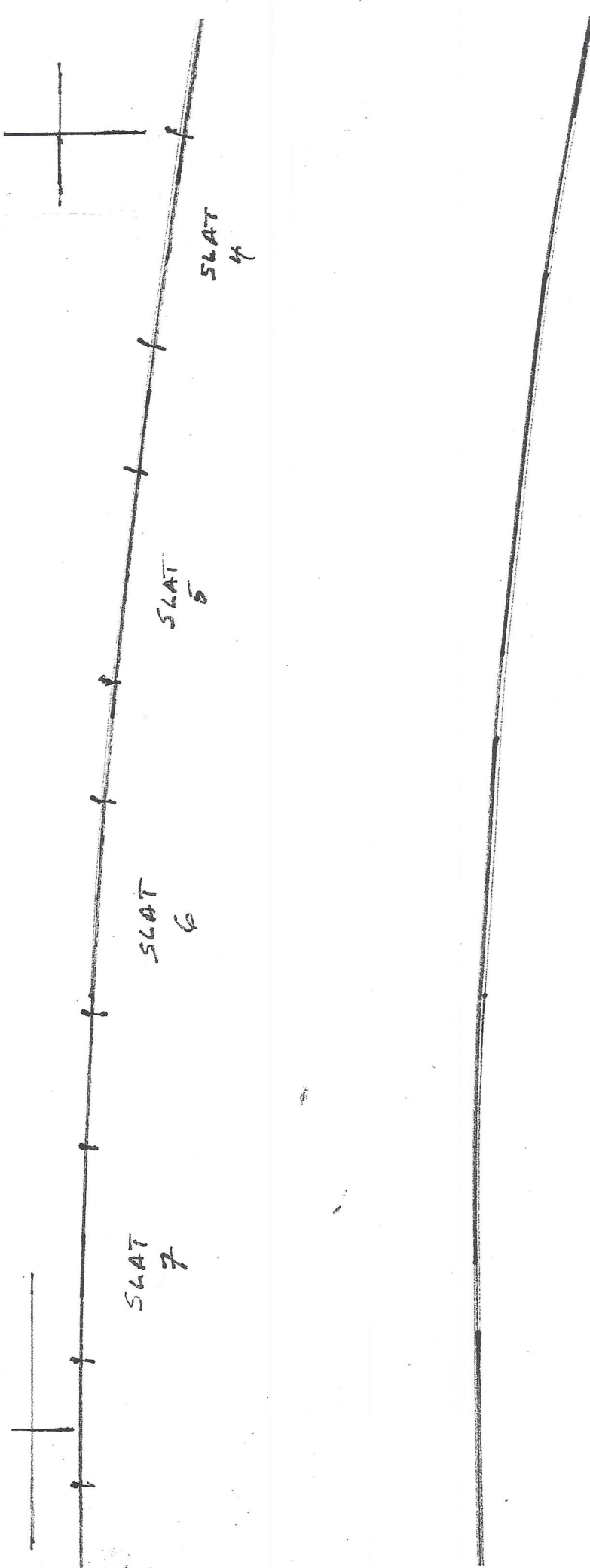

SLAT
4

SLAT
5

SLAT
6

SLAT
7

Seat Stile Pg 10/13

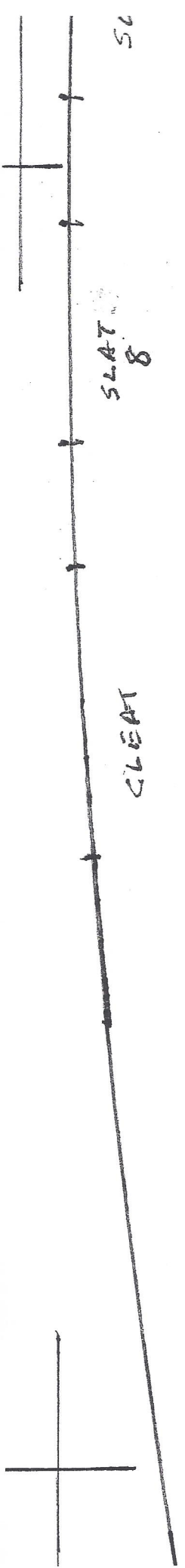

SEAT REST SIDE

Seat Stile Pg 11/13

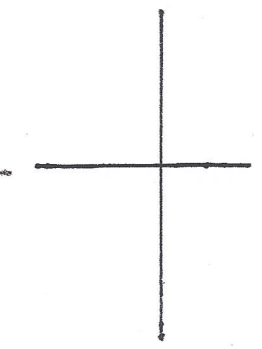

3

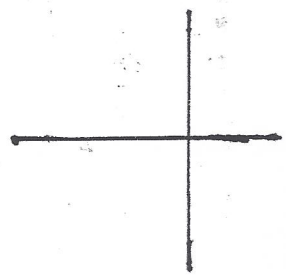

Seat Stile Pg 12/13

STRETCHER
SCREW HOLES

4

**Seat
Stile
Pg 13/13**



5