

Body Top view
Scale: 1:1

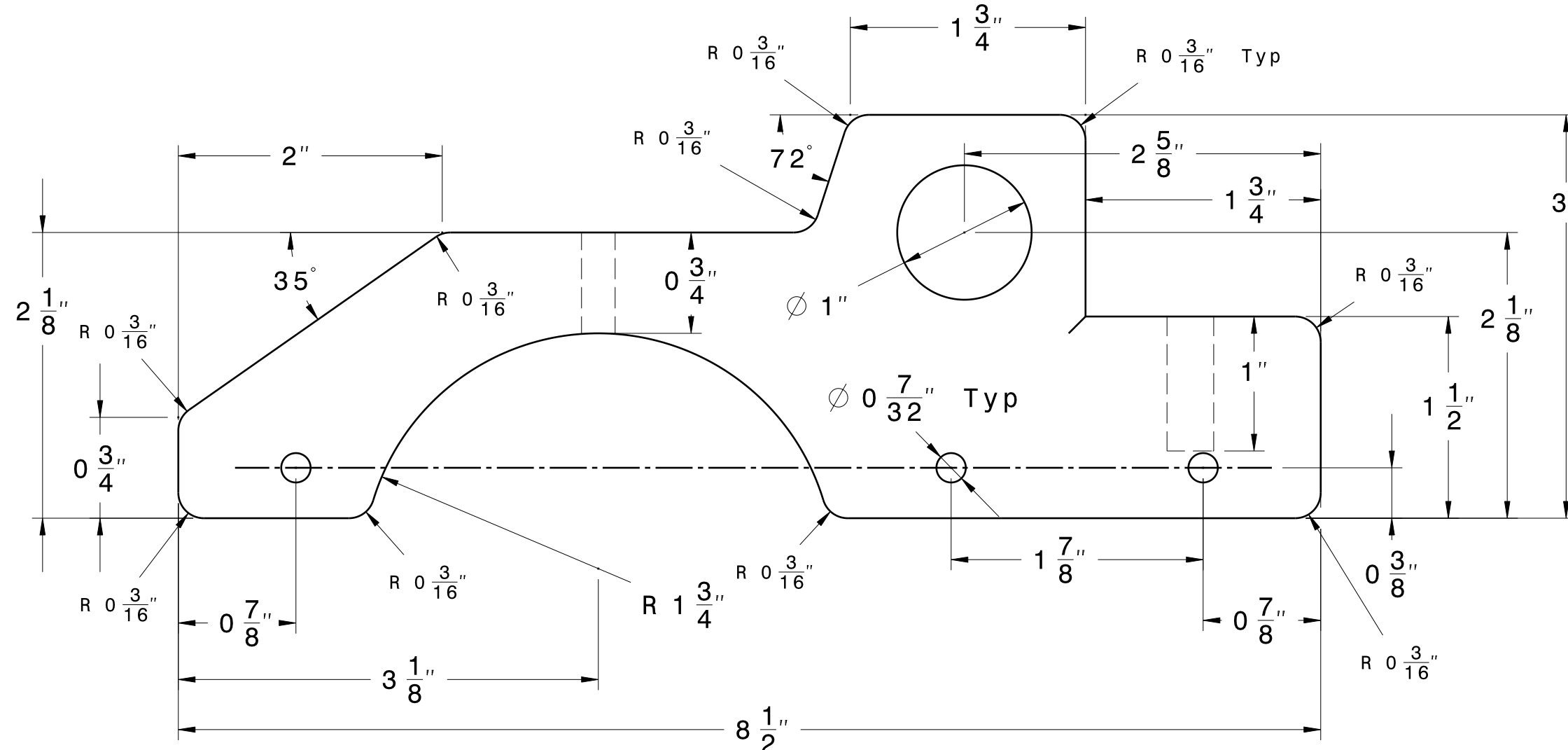

Body
Scale: 1:1

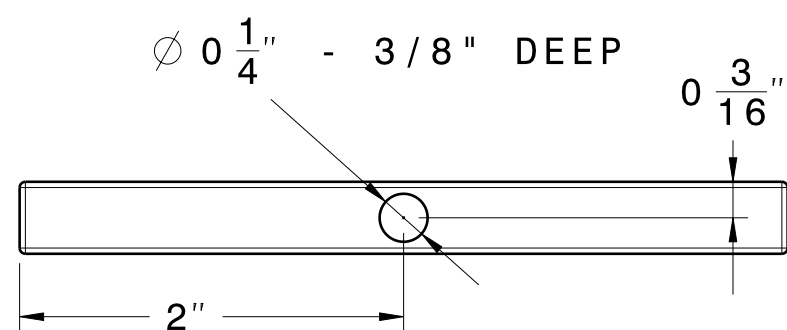

Blade Top view
Scale: 1:1

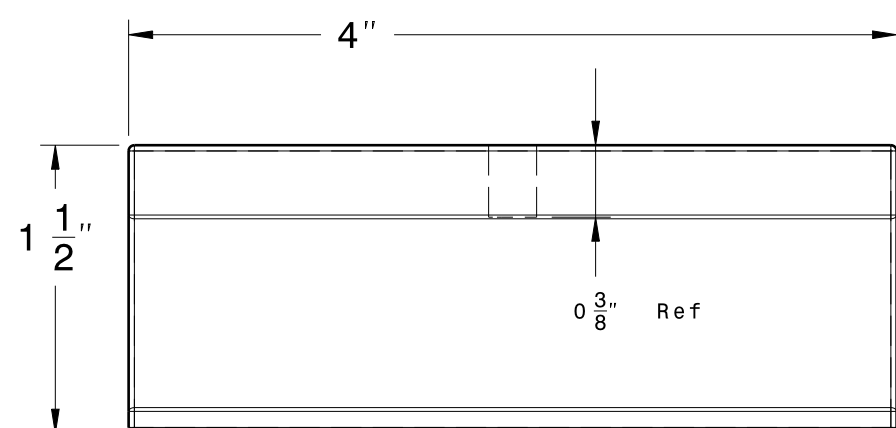

Blade
Scale: 1:1

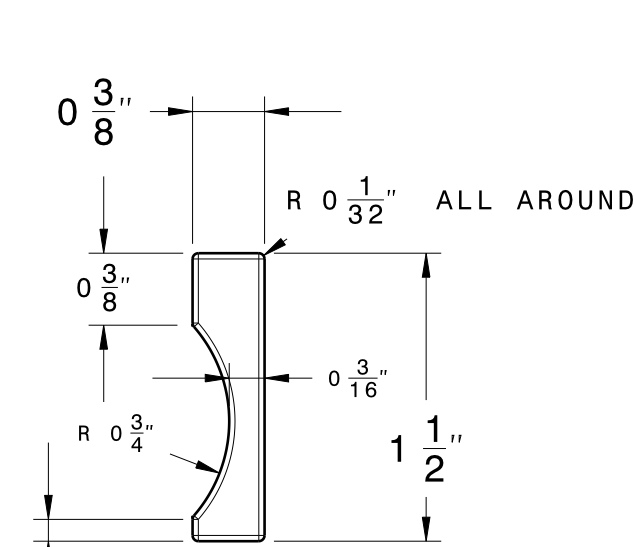

Blade Side view
Scale: 1:1

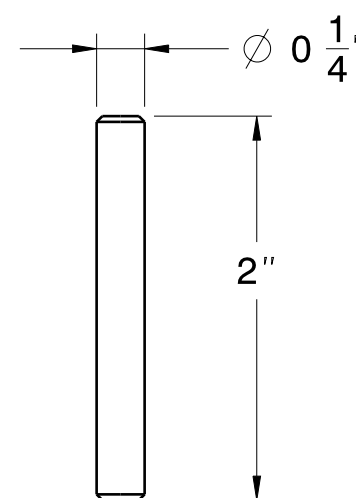

Blade Pivot Shaft
Scale: 1:1

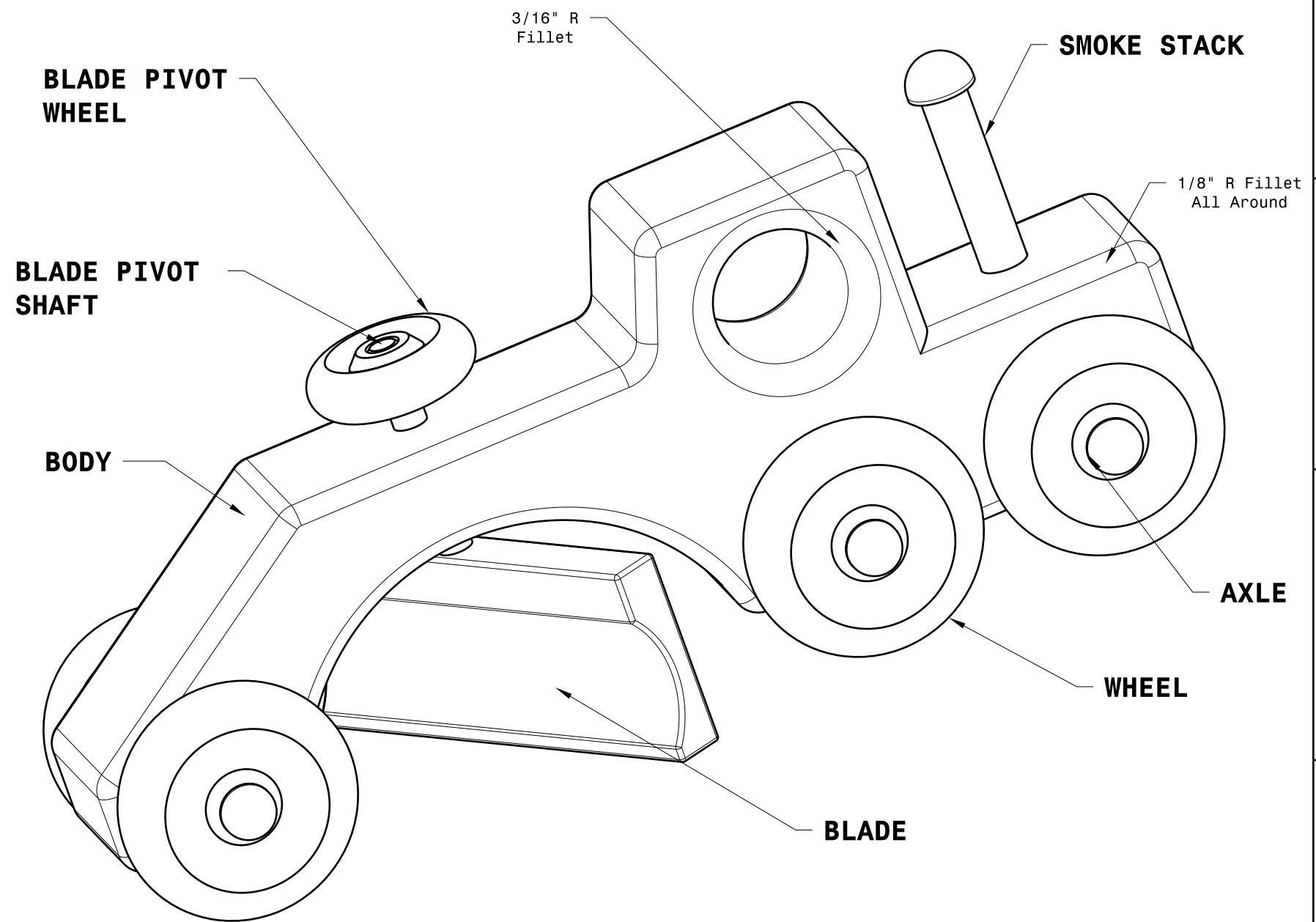

Isometric view
Scale: 1:1

MATERIAL LIST			
Component Description	Number Req'd	Size	Material
Body	1	8-1/2" x 3" x 1-1/2"	Ash
Blade	1	4" x 1-1/2" x 3/8"	Ash
Blade Pivot Shaft	1	1/4" Dia. x 2" Long	Pine
Blade Pivot Wheel	1	1-1/4" Dia	Pine
Smoke Stack	1	11/32" Dia X 2-3/8" Long	Pine
Wheel	6	1-3/4" Dia	Pine
Axle	6	7/32" X 1" Long	Pine

This drawing is our property. It can't be reproduced or communicated without our written agreement.

DAN HOLOWICKI DESIGN			
DRAWING TITLE Dan's Construction Grader			
DRAWN BY D.R. McCagg	DATE 60CT2023	SIZE C	
CHECKED BY XXX	DATE XXX	DRAWING NUMBER Dans Grader 10-2-23	REV Rel
DESIGNED BY D.R. McCagg	DATE 60CT2023	SCALE 1:1	WEIGHT(kg) 3.60
			SHEET 1/1